



创意源于追求
Own Idea Of Lighting

PLUTO 550 HYBRID

USER MANUAL



PLUTO 550 HYBRID
SS9171

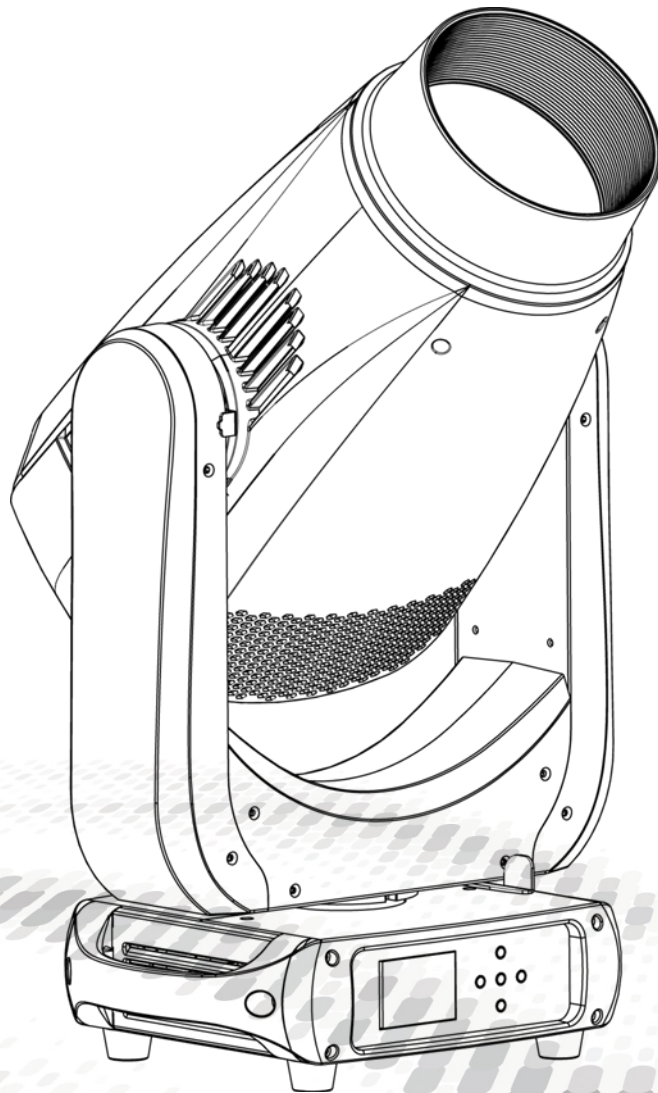

MODEL: SS9171SC



广州市雅江光电设备有限公司
Guangzhou Yajiang Photoelectric Equipment Co., Ltd.
电话/Tel: 020-86947788 邮箱/E-mail: sales@yajiang.cn
传真/Fax: 020-86943773 网址/Website: www.yajiang.cn

— Since 1985 —

1 PRODUCT

1.1 TECHNICAL SPECIFICATIONS

Type	SS9171SC
LED colors	450W Cool White LED
Power	550W
Voltage Range	AC100~240V,50/60Hz
Protection	IP20
Operation Temperature	0°C~45°C
Dimensions	380x251x710mm
Weight	26kg

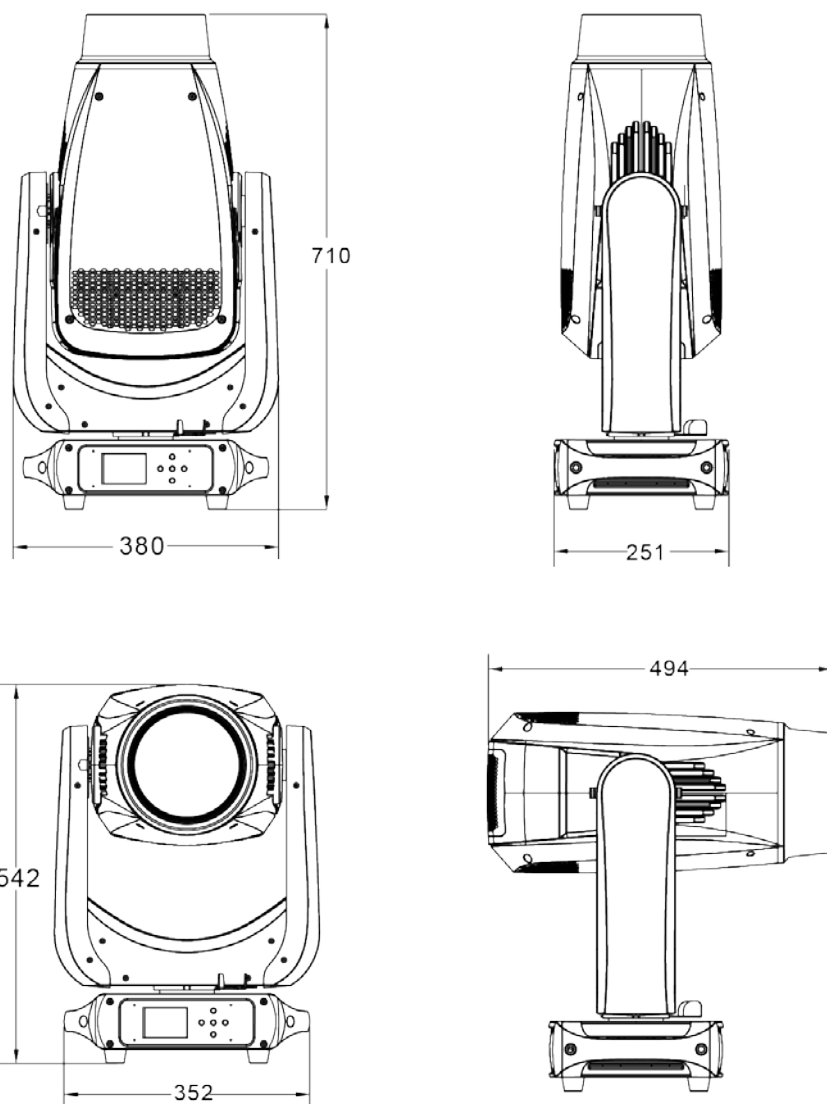

1.2 Safety Notes

IMPORTANT

- This product must be installed by a qualified professional.
- In order to maintain this condition and to ensure a safe operation, it is absolutely necessary for the user to follow the safety instructions and warning notes
- The manufacturer will not accept liability for any resulting damages caused by the non-observance of this manual or any unauthorized modification to the device.

CAUTION!

- Make sure that the available voltage is not higher than stated on the rear panel.
- Do not touch the power cables if your hands are wet.
- The earth wire must always be connected to the ground. Therefore it is essential to connect the yellow/green conductor to earth.
- Make sure that the power-cord is never crimped or damaged by sharp edges. Check the device and the power-cord from time to time. The electric connection, repairs and servicing must be carried out by a qualified employee.
- Always disconnect power input cable to completely remove power from unit when not in use or before cleaning or servicing the fixture.
- Do not switch the fixture on and off in short intervals as this would reduce the lamp's life.
- Do not touch the device's housing bare hands during its operation (housing becomes hot)! The surface of the product's casing can reach up to 70° C (158° F) during operation. Avoid contact by persons and materials. Do not install the product in a location where there is a risk of accidental contact. Allow the product to cool for at least 10 minutes before handling.
- For replacement use lamps and fuses of same type and rating only.
- Please protect the fixture and avoid destroy during transport and installation. If there is any damage to the coating, the shell may be corroded.
- When hanging lamps and lanterns, it is necessary to verify that facilities and hooks can bear at least 10 times the weight of lamps and lanterns.
- Fix the safety rope at the correct holes only. Only operate the fixture after having checked that the housing is firmly closed and all screws are tightly fastened.
- The maximum ambient temperature 45°C must never be exceeded. Do not operate the product if the ambient temperature (Ta) exceeds 45° C (115° F).
- During the initial start-up some smoke or smell may arise. This is a normal process and does not necessarily mean that the device is defective.

Electrical Warning

- The light source contained in this luminaire shall only be replaced by the manufacturer or his service agent or a similar qualified person
- For replacement use lamps and fuses of same type and rating only.
- The lens has to be replaced when it is obviously damaged, so that its function is impaired, e. g. due to cracks or deep scratches!

Keep the product well away from flammable materials

- Keep all combustible materials (e.g. fabric, wood, paper) at least 500 mm (20 in.) away from the product.
- Ensure that there is free and unobstructed airflow around the product. Provide a minimum clearance of 150 mm (6 in.) around fans and air vents.
- Do not illuminate surfaces within 3 m (10 ft.) of the product.
- Do not install a fuse that has a higher rating than the one originally installed in the product. Do not bypass fuses.
- Do not stick filters, masks or other materials onto optical components.
- If the fixture seems to be abnormally hot, shows signs of melting or emits smoke, disconnect the fixture from power immediately and allow it to cool. Do not touch the fixture without heatproof safety gloves. Keep the fixture well away from combustible and flammable materials.

**NEVER LOOK DIRECTLY INTO THE LIGHT SOURCE!
RETINA INJURY RISK - MAY INDUCE BLINDNESS!**

Do not point the front of the fixture towards the sun or other strong light sources. The front lens focuses and concentrates light just like a magnifying glass. Strong light can cause internal damage to the fixture, melting components or starting an internal fire within seconds.

To avoid problems from strong light sources:

- Do not expose the front of a fixture to sunlight or any other strong light source. Avoid pointing other high-powered beam lights directly at the fixture.
- Do not focus a light beam from one lighting fixture directly towards another.
- For outdoor applications during daylight, make sure that the front face of any fixture is shielded or points away from the sun, even when not in use.
- Do not expose the product to heat (from other lighting fixtures for example).

2 INSTALLATION

2.1 MOUNTING

Truss installation

- ◆ Keep all combustible materials (e.g. fabric, wood, paper) at least 500 mm (20 in.) away from the product.
- ◆ For overhead use, always install a safety cable that can hold at least 10 times the weight of the fixture.
- ◆ For overhead installation, the fixture must be always secured with a safety wire that can bear at least 10 times the weight of the fixture;
- ◆ Secure the fixture with a safety cable through the rear safety eye and truss as shown..
- ◆ Ensure that the structure (truss) to which you are attaching the fixture is secure

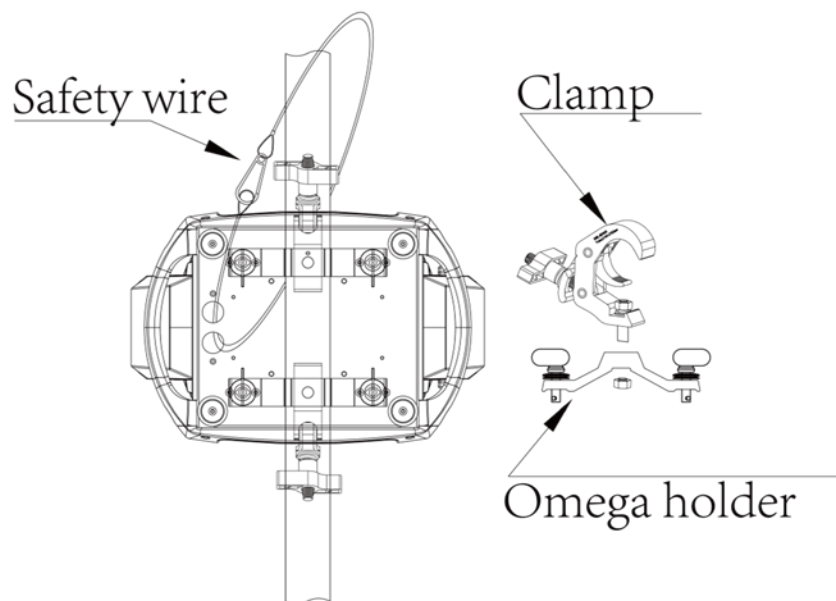

2.2 Fuse replacement

- ◆ Remove the safety cap by a screwdriver.
- ◆ Fetch the old fuse from safety cap.
- ◆ Install a new fuse.
- ◆ Install the safety cap.

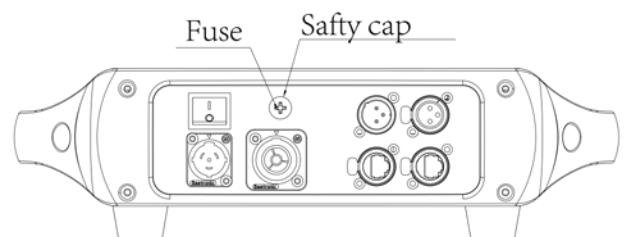

2.3 POWER CONNECTIONS

- ◆ This product has an auto-ranging power supply that can work with an input voltage range of 100–240 VAC, 50/60 Hz.

2.4 Data network requirements

- ◆ Connect the DMX512 controller to the units in series. A DMX 512 data link is required in order to control the fixture via DMX. The fixture has 3/5-pin XLR connectors for DMX data input and output.
- ◆ Each unit has 13 DMX channels so the DMX Addresses should increase by increments of 1, (Nx1)+1, (Nx2)+1, (Nx3)+1...
- ◆ Any DMX address in the range from 001 to 512 may be used.
- ◆ Connect the DMX-output of the first fixture in the DMX chain with the DMX-input of the next fixture. Always connect one output with the input of the next fixture until all fixtures are connected.
- ◆ Caution: At the last fixture, the DMX-cable has to be terminated with a terminator. Solder a 120 Ω resistor between Signal (-) and Signal (+) into a 3/5-pin XLR-plug and plug it in the DMX-output of the last fixture.

DMX-output
XLR mounting-sockets

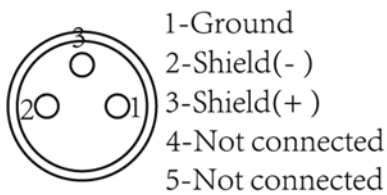

DMX-input
XLR mounting-plugs

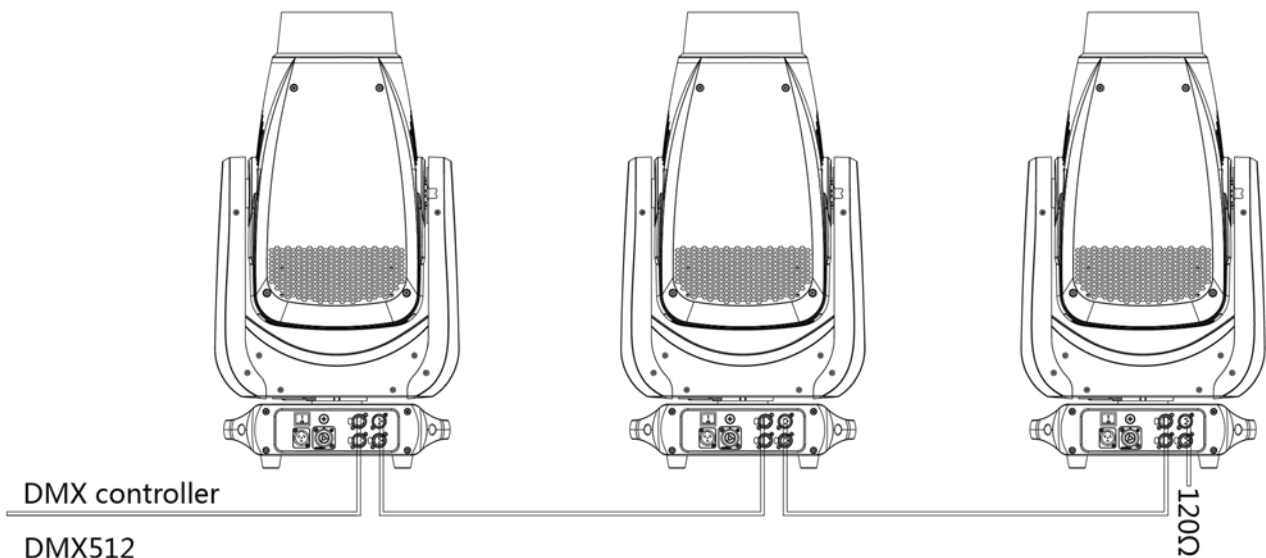
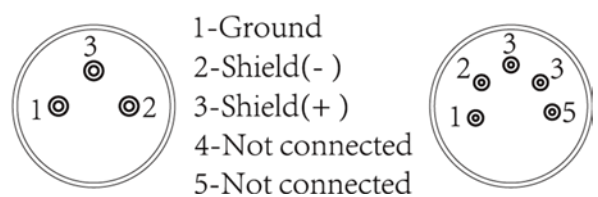

3 FUNCTIONS AND SETTINGS

3.1 DISPLAY OPERATION

- ◆ MENU: Used to access the menu or to return a previous menu option;
- ◆ ENTER: Used to select and store the current menu or confirm the current function value or option within a menu;
- ◆ UP: Navigates downwards through the menu list and increases the numeric value when in a function;
- ◆ DOWN: Navigates upwards through the menu list and decreases the numeric value when in a function;

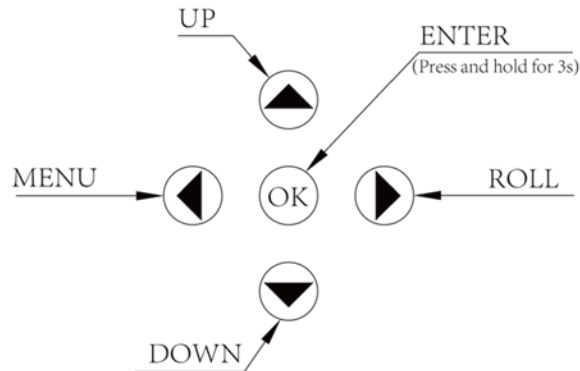

3.2 Menu Map

ADDRESS	001 – 512(Default 001)		DMX address setting
PERSON	BASIC		Use the menu to select desired channel mode
	STANDARD (Default)		
	EXTEND		
RUNMODE	DMX512 (Default)		Select Signal
	ARTNET		Default: DMX512
	sACN		CUSTOM1-2 Set up get into EDIT MENU
	ARTNET TO DMX		edit
	AUTO		
	CUSTOM1		
	CUSTOM2		
OPTION	PAN INVERT	NORMAL (Default)	PAN moving direction selection
		INVERT	
	TILT INVERT	NORMAL (Default)	TILT moving direction selection
		INVERT	
	PERFORM	STUDIO	Fan mode low speed
		POWER	Fast rotation of fan, all power
		LIVE (Default)	Automatic rotation of fan
	BLACKOUT	OFF (Default)	Select OFF blackout without delay
		ON	Select ON Blackout delay 3s
	DIMMER	DIM4 (Default)	Dimming curves DIM1 (fast) to DIM4 (slow);
		DIM3	
		DIM2	
DIM1			
OFF			

	LED PWM	1200Hz (Default)		Sets the PWM frequency	
		2400Hz			
		4000Hz			
		6000Hz			
		25000Hz			
DMX ERROR	SAVE (Default)		Hold after loss of DMX signal		
	BLACK		Blackout after loss of DMX signal		
DISPLAY TIME	On		Display backlight always on		
	30s		Turns off display backlight after 30s/1min /2min of inactivity		
	1min				
	2min				
DISPLAY LOCK	OFF		Locks display (passcode is <UP>, <DOWN>,<UP>, <DOWN>, <ENTER>)		
	ON (Default)				
LOAD PARA	YES		Upload data		
	NO		Not upload data		
SETTING	RECOVERY	****		Restore default factory settings.	
	CLEAN EDIT1	****		Clean customer self-editing scene 1	
	CLEAN EDIT2	****		Clean customer self-editing scene 2	
	WDMX HIDE	YES		Hide wireless mode WDMX reset and signal hide and the default is wired mode only	
NO					
NETWORK	Net SWITCH	2.XXX.XXX.XXX		Net switch off IP mode	
		10.XXX.XXX.XXX		Net switch on IP mode	
	UNIVERS	0-255		Packet group Settings	
	IP MODE	DEFAULT IP		Default IP	
		CUSTOM IP		Customer's IP	
CUSTOM IP	XX.XX.XX.XX		Customer's IP setting		
PT ENCODER	OFF		XY Encoder switch.		
	ON		OFF is close; ON is open.		
WDMX RESET	YES		Clear the receiver's message		
	NO		Do not clear the receiver's message.		
SIGNAL	ONLY XLRDMX		ONLY XLR is wire only		
	XLRDMX FIRST		XLR FIRST is wire first		
	ONLY WDMX		ONLY WDMX is wireless only		
	WDMX FIRST		WDMX FIRS is wireless first		
	WDMX TO XLRDMX		WDMX TO DMX is wireless to wired		
EDIT	EDIT 1-2	STEP 1-30	PAN	0-255	Edit the custom programs1-30 Select play 【EDIT 1】 in RUNMOEDE CUSTOM 1; Select play 【EDIT 2】 in RUNMOEDE CUSTOM 2
			TILT	0-255	
	PT SPEED		0-255		
	CMY C		0-255		
	CMY M		0-255		
	CMY Y		0-255		
	COLOR		0-255		
	FIXED GOBO		0-255		
	ROTA.GOBO		0-255		
	GOBO. ROTA		0-255		

			ANIMATION.D	0-255	
			ANIMATION.R	0-255	
			PRISM 1	0-255	
			PRISM 2	0-255	
			FROST	0-255	
			ZOOM	0-255	
			FOCUS	0-255	
			DIMMER	0-255	
			STROBE	0-255	
			TIME	0-255	
			USE	YES/NO	Select YES to run the steps user need.
MANUAL	AUTO TEST				
	CHANNEL	PAN	0-255		Manual control channel
		TILT	0-255		
		PT SPEED	0-255		
		CMY C	0-255		
		CMY M	0-255		
		CMY Y	0-255		
		COLOR	0-255		
		FIXED GOBO	0-255		
		ROTA.GOBO	0-255		
		GOBO. ROTA	0-255		
		ANIMATION	0-255		
		PRISM 1	0-255		
		PRISM 2	0-255		
		FROST	0-255		
		ZOOM	0-255		
	FOCUS	0-255			
	DIMMER	0-255			
	STROBE	0-255			
	DEBUG HIDE	YES		Factory testing mode. All stepper motors are not controlled by signal, It only works again after the reset.	
NO					
RESET	ALL RESET		Select Yes/No to carry out all reset		
	PT RESET		Select Yes/No to carry out P/T reset		
	COLOR SYS		COLOR/CMYK reset		
	OTHER		Zoom/ Focus/ Prism reset		
INFO	FIXTURE HOURS		Hours of fixture use		
	LED USE HOURS		LED use time		
	TEMPERATURE		LED temperature		
	VERSION		Software versions		
	NETWORK		Check network parameter		
	RDM	UID	0x388Axxxxxxxx		Check fixture's ID
		LABEL	PLUTO 550 HYBRID		Check fixture's LABEL
	SYSTEM	MEMORY IC		Memory IC	
ERROR	ANGLE SENSOR		Angle Sensor		

		PAN SENSOR		Pan Sensor
		PAN ENCODER		Pan Encoder
		PAN DRIVE IC		Pan Drive IC
		TILT SENSOR		Tilt Sensor
		TILT ENCODER		Tilt Encoder
		TILT DRIVE IC		Tilt Drive IC
		TEMPERATURE		Temperature
		CMY C RESET		CMY C Reset
		CMY M RESET		CMY M Reset
		CMY Y RESET		CMY Y Reset
		COLOR RESET		Color Reset
		F GOBO RESET		Fixed Gobo Reset
		GOBO RESET		Gobo Reset
		R GOBO RESET		Rotate Gobo Reset
		ANIMATION RESET		Animation Reset
		PRISM 1 RESET		Prism 1 Reset
		PRISM 2 RESET		Prism 2 Reset
		ZOOM RESET		Zoom Reset
		FOCUS RESET		Focus Reset
SERVICE	****	PAN	±127	Pan position fine adjustment
		TILT	±127	Tilt position fine adjustment
		CMY C	±127	CMY-C position fine adjustment
		CMY M	±127	CMY-M position fine adjustment
		CMY Y	±127	CMY-Y position fine adjustment
		COLOR	±127	Color position fine adjustment
		FIXED GOBO	±127	Fixed Gobo position fine adjustment
		ROTA. GOBO	±127	Rotate Gobo position fine adjustment
		GOBO.ROTA	±127	Self-rotation position fine adjustment
		ANIMATION WHEEL	±127	Animation position fine adjustment
		PRISM 1	±127	Prism 1 position fine adjustment
		PRISM 2	±127	Prism 2 position fine adjustment
		FROST	±127	FROST position fine adjustment
		ZOOM	±127	Zoom position fine adjustment
		FOCUS	±127	Focus position fine adjustment

4 USING A DMX512 CONTROLLER

4.1 DMX CONTROL

BASIC (23CH)	STANDARD (29CH)	Extend (31CH)	Value	Function
CH.1	CH.1	CH.1	000-255	PAN 0-540°
-	CH.2	CH.2	000-255	PAN FINE
CH.2	CH.3	CH.3	000-255	TILT 0-270°
-	CH.4	CH.4	000-255	TILT FINE
CH.3	CH.5	CH.5	000-255	PT Speed
CH.4	CH.6	CH.6	000-255	CYAN
CH.5	CH.7	CH.7	000-255	MAGENTA
CH.6	CH.8	CH.8	000-255	YELLOW
CH.7	CH.9	CH.9	000-255	COLOUR MACRO
			COLOUR MACRO	
			000-010	No Function
			11-20	L106
			21-30	L194
			31-40	L019
			41-50	R08
			51-60	L213
			61-70	R80
			71-80	L202
			81-90	L328
			91-100	R3314
			101-110	L101
			111-120	L768
			121-128	No Function
			129-147	CYAN 100% / MAGENTA UP / YELLOW 0%
			148-166	CYAN DOWN / MAGENTA 100% / YELLOW 0%
			167-185	CYAN 0% / MAGENTA 100% / YELLOW UP
			186-204	CYAN 0% / MAGENTA DOWN / YELLOW 100%
			205-223	CYAN UP / MAGENTA 0% / YELLOW 100%
224-242	CYAN 100% /MAGENTA 0%/YELLOW DOWN			
243-255	CYAN 100%/MAGENTA UP/YELLOW 0%			
CH.8	CH.10	CH.10	000-255	CMYK SPEED(SPEED 100%->1)
CH.9	CH.11	CH.11	000-255	COLOR WHELL
			COLOR WHELL 6+1	
			000-015	WHITE
			016-023	COLOR 1

			024-031	COLOR 2
			032-039	COLOR 3
			040-047	COLOR 4
			048-055	COLOR 5
			056-063	COLOR 6
			064-191	COLOR WHELL 0-360°
			192-222	COLOR WHELL RAINBOW EFFECT(SPEED 100%→1)
			223-224	STOP
			225-255	COLOR WHELL RAINBOW EFFECT (SPEED 1→100%)
-	-	CH.12	000-255	COLOR WHELL FINE
CH.10	CH.12	CH.13	000-255	ROTATING GOBO
			ROTATING GOBO 8+1	
			000-010	ROTATING WHITE
			011-016	ROTATING GOBO 1
			017-022	ROTATING GOBO 2
			023-028	ROTATING GOBO 3
			029-034	ROTATING GOBO 4
			035-040	ROTATING GOBO 5
			041-046	ROTATING GOBO 6
			047-052	ROTATING GOBO 7
			053-058	ROTATING GOBO 8
			059-066	ROTATING GOBO 1 SHAKE (SPEED 1 → 100%)
			067-074	ROTATING GOBO 2 SHAKE (SPEED 1 → 100%)
			075-082	ROTATING GOBO 3 SHAKE (SPEED 1 → 100%)
			083-090	ROTATING GOBO 4 SHAKE (SPEED 1 → 100%)
			091-098	ROTATING GOBO 5 SHAKE (SPEED 1 → 100%)
			099-106	ROTATING GOBO 6 SHAKE (SPEED 1 → 100%)
			107-114	ROTATING GOBO 7 SHAKE (SPEED 1 → 100%)
			115-122	ROTATING GOBO 8 SHAKE (SPEED 1 → 100%)
			123-127	WHITE
			128-190	ROTATING GOBO FLOWING WATER EFFECT (SPEED 100 → 1%)
			191-192	STOP WATER EFFECT
			193-255	ROTATING GOBO FLOWING WATER EFFECT (SPEED 1 → 100%)
CH.11	CH.13	CH.14	000-255	GOBO ROTATING
			GOBO ROTATING	
			0-120	ROTATING GOBO ANGLE ADJUSTMENT (0 → 360°)
			121-125	STOP
			126-165	ROTATING GOBO SHAKE (SPEED 1 → 100%)
			166-170	STOP
			171-210	ROTATING GOBO POSITIVE ROTATION (SPEED 100% → 1)

			211-215	STOP
			216-255	ROTATING GOBO REVERSE ROTATION (SPEED 1 → 100%)
-	CH.14	CH.15	000-255	GOBO ROTATING FINE
CH.12	CH.15	CH.16	000-255	FIXED GOBO WHEEL
			FIXED GOBO WHEEL 10+1	
			0-10	WHITE
			11-17	FIXED GOBO WHEEL 1
			18-24	FIXED GOBO WHEEL 2
			25-31	FIXED GOBO WHEEL 3
			32-38	FIXED GOBO WHEEL 4
			39-45	FIXED GOBO WHEEL 5
			46-52	FIXED GOBO WHEEL 6
			53-59	FIXED GOBO WHEEL 7
			60-66	FIXED GOBO WHEEL 8
			67-73	FIXED GOBO WHEEL 9
			74-80	FIXED GOBO WHEEL 10
			81-87	FIXED GOBO WHEEL 1 SHAKE (SPEED 1 → 100%)
			88-94	FIXED GOBO WHEEL 2 SHAKE (SPEED 1 → 100%)
			95-101	FIXED GOBO WHEEL 3 SHAKE (SPEED 1 → 100%)
			102-108	FIXED GOBO WHEEL 4 SHAKE (SPEED 1 → 100%)
			109-115	FIXED GOBO WHEEL 5 SHAKE (SPEED 1 → 100%)
			116-122	FIXED GOBO WHEEL 6 SHAKE (SPEED 1 → 100%)
			123-129	FIXED GOBO WHEEL 7 SHAKE (SPEED 1 → 100%)
			130-136	FIXED GOBO WHEEL 8 SHAKE (SPEED 1 → 100%)
			137-143	FIXED GOBO WHEEL 9 SHAKE (SPEED 1 → 100%)
			144-150	FIXED GOBO WHEEL 10 SHAKE (SPEED 1 → 100%)
151-200	STATIC GOBO JUMPING WATER EFFECT (SPEED 100 → 1%)			
201-205	STOP WATER EFFECT			
206-255	STATIC GOBO FLOWING WATER EFFECT (SPEED 1 → 100%)			
CH.13	CH.16	CH.17	0-255	INSERT EFFECT WHEEL
CH.14	CH.17	CH.18	000-255	ANIMATION
			ANIMATION DISC ROTATION	
			0-10	WHITE
			11-127	Animation Insertion CW Rotate Slow to Fast
			128-138	Rotation STOP
139-255	Animation Insertion CCW Rotate Fast to Slow			
CH.15	CH.18	CH.19	000-255	PRISM
			PRISM 1	
			0-10	WHITE
			11-145	PRISM INSERT AND ADJUST THE ANGLE (0 → 360°)

			146-150	STOP
			151-200	PRISM INSERT AND POSITIVE ROTATION (SPEED 100% → 1)
			201-205	STOP ROTATION
			206-255	PRISM INSERT AND REVERSE ROTATION (SPEED 1 → 100%)
CH.16	CH.19	CH.20	000-255	PRISM
			PRISM 2	
			0-10	WHITE
			11-145	PRISM INSERT AND ADJUST THE ANGLE (0 → 360°)
			146-150	STOP
			151-200	PRISM INSERT AND POSITIVE ROTATION (SPEED 100% → 1)
			201-205	STOP ROTATION
			206-255	PRISM INSERT AND REVERSE ROTATION (SPEED 1 → 100%)
CH.17	CH.20	CH.21	000-255	FROST
			FROST	
			0-10	NO FUNCTION
			11-255	LINEAR CUT (0-100%)
CH.18	CH.21	CH.22	000-255	ZOOM
-	CH.22	CH.23	000-255	ZOOM FINE
CH.19	CH.23	CH.24	000-255	FOCUS
-	CH.24	CH.25	000-255	FOCUS FINE
CH.20	CH.25	CH.26	000-255	AUTO FOCUS
			AUTO FOCUS	
			0-12	NO FUNCTION
			13-39	5 METER
			40-66	7 METER
			67-93	9 METER
			94-120	11 METER
			121-147	13 METER
			148-174	15 METER
			175-201	17 METER
			202-228	19 METER
			229-255	21 METER
-	-	CH.27	000-255	AUTO FOCUS FINE
CH.21	CH.26	CH.28	000-255	DIMMER
-	CH.27	CH.29	000-255	DIMMER FINE
CH.22	CH.28	CH.30	000-255	STROBE
			STROBE	
			0-9	NO FUNCTION
			10-99	STROBE (FROM SLOW TO FAST)
			100-109	NO FUNCTION

			110-179	LIGHTNING STROBE
			180-189	NO FUNCTION
			190-255	RANDOM SROBE
CH.23	CH.29	CH.31	000-255	CONTROL
			CONTRO (LEXECUTE AFTER 3 SECONDS)	
			000-010	NO FUNCTION
			011-020	PAN/TILT BLACK ACTIVATED
			021-030	PAN/TILT BLACK DEACTIVATED
			031-040	PAN INVERT
			041-050	TILT INVERT
			051-060	PAN/TILT INVERT OFF
			061-070	STUDIO
			071-080	POWER
			081-090	LIVE
			091-100	RESERVED
			101-110	DIM4
			111-120	DIM3
			121-130	DIM2
			131-140	DIM1
			141-150	OFF
			151-160	1200Hz
			161-170	2400Hz
			171-180	4000Hz
			181-190	6000Hz
			191-200	25000Hz
			201-210	ALL RESET
			211-220	XY RESET
			221-230	COLOR\GOBO SYSTEM RESET
231-240	FOCUS\ZOOM RESET			
241-255	RESERVED			