

F6

FREZNO ze-3HD SS811SW HD/SC HD



PRODUCT INTRODUCTION

This fixture is specialized designed for Theater, TV, and Studio. High powerful light, High CRI, Continuation of energy conservation and environmental protection. High efficient brand idea. Electronic zoom 15°-60°, 16bit dimmer smooth, no shake.

PRODUCT PARAMETERS

Optical system

SS811SW HD/SC HD

Light source	300W
Luminous flux	17000lm/18000lm
CCT	3200K, 5600K
CRI/CQS/TLCI	Ra:98/96/98
Angle	15°-60°

Appearance

Size	485x333x322mm
Weight	7.8kg
Casing	Extruded aluminum
Color	Black

Electrical Specs

Voltage	AC100-240V, 50/60Hz
Max. Power	300W
Power Connection	Power in and out
DMX XLR	DMX in and out

Control System

Dimmer	0-100% 16Bit
Cooling	Forced Convection
Control	DMX512
Display	On board Control, 0-25Hz Strobe

Con Personality UNO(1CHS)、DOS(2CHS)、STD.P(5CHS)

Certification

CE, MET

Work Environment

Ambient Temp	0°C-45°C
IP Rated	IP20

ILLUMINANCE AT DISTANCE

SS811SW HD

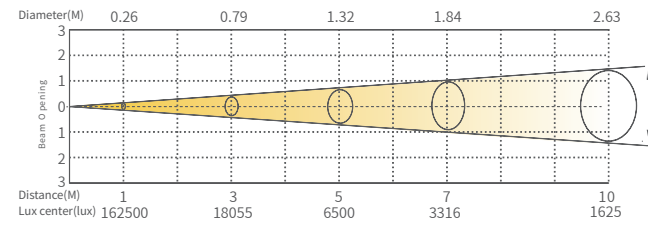

SS811SC HD

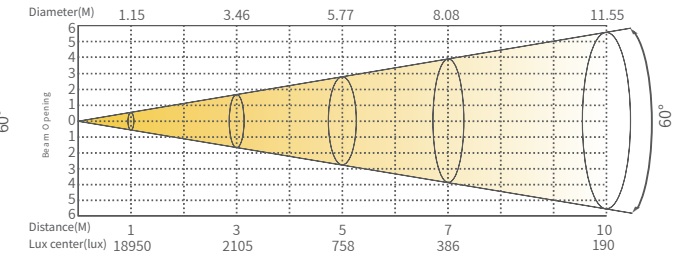
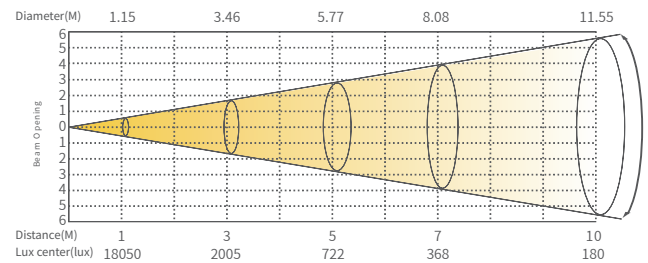
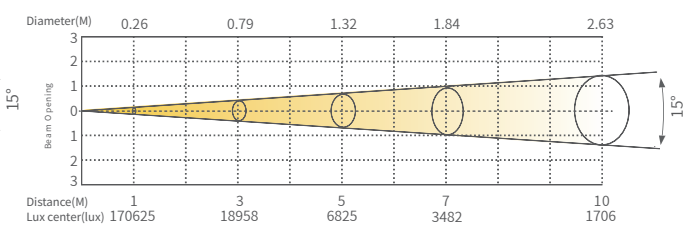

DIMENSIONS

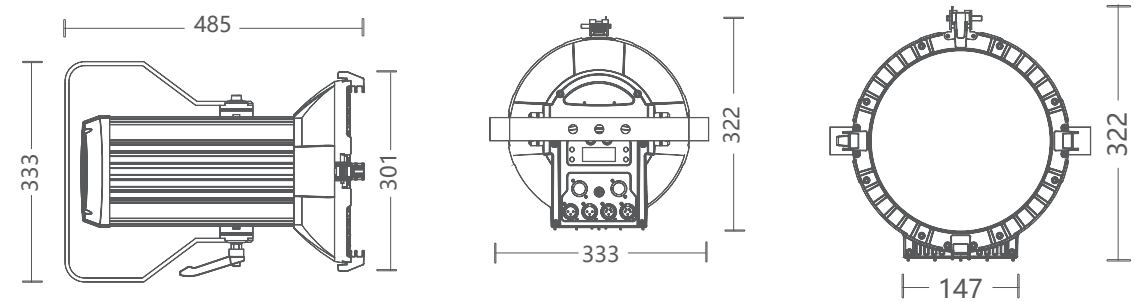

ACCESSORIES (Accessories not included unless otherwise stated)

