

FC7

FREZNO ze-2 RGBAL

SS815XAL



PRODUCT INTRODUCTION

As an innovative 5 color Fresnel, FREZNO ze-2RGBAL is applied with high-effective optics system, thus generating in excellent color-mixing performance. With HSIC intelligent system, you can mix any color you wanted easily. Color temperatures from 1800K to 10000K, 16 kinds of professional color are programmed. It is an ideal product for professional lighting in TV station, studio, exhibition, conference hall, theater etc.

PRODUCT PARAMETERS

Optical system

Light source	200W RGBAL
Luminous flux	9362lm
CCT	1800K-10000K
CRI	Ra≥90
Angle	15°-45°

Appearance

Size	510x285x261mm
Weight	7.6kg
Casing	Extruded aluminum
Color	Black

Electrical Specs

Voltage	AC100-240V, 50/60Hz
Max. Power	240W
Power Connection	Power in and out
DMX XLR	DMX in and out

Control System

Dimmer	0-100% 16Bit
Cooling	Forced Convection
Control	DMX512, RDM
Display	On board Control, 0-25Hz Strobe

Con Personality HSIC(8CHS), SSP(10CHS), TOUR(13CHS), TR16(19CHS)

Certification

CE, MET

Work Environment

Ambient Temp	0°C-45°C
IP Rated	IP20

ILLUMINANCE AT DISTANCE

3200K

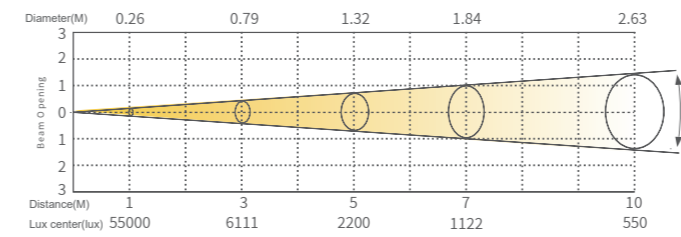

5600K

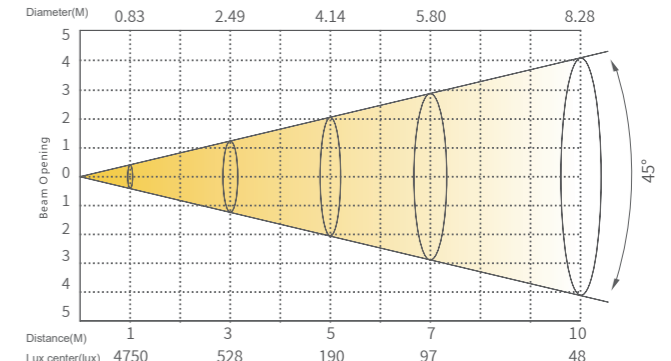
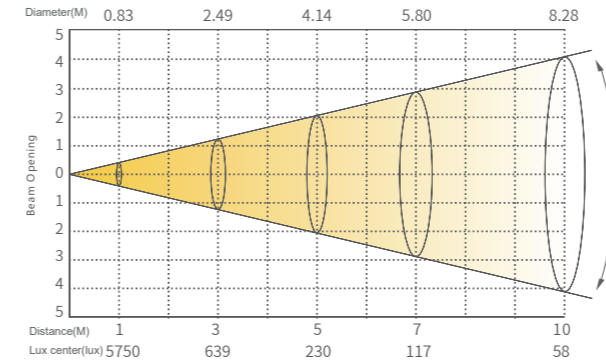
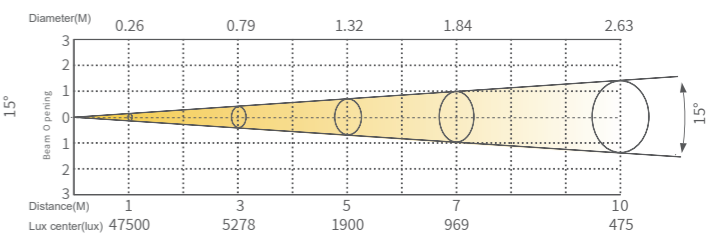

DIMENSIONS

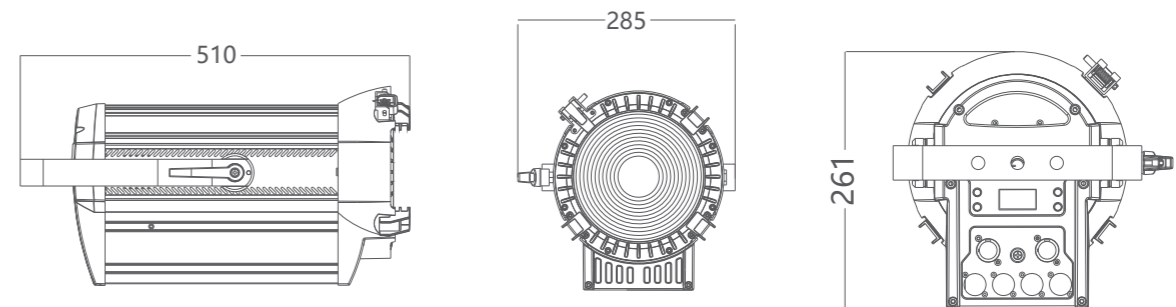

ACCESSORIES (Accessories not included unless otherwise stated)

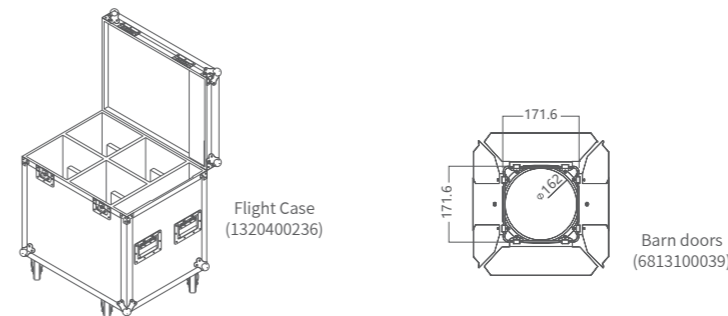

STAGER

FULL COLOR